

FIBERSTRONG®

# 3° Angularly Deflected Double Bell Coupling Joint

Reliability in Glass Reinforced Polyester and Vinylester Pipe Systems

SUMMARY:

A new FPI Product that allows the elimination of small angle elbows, increasing the potential for large angle elbows. This eliminates all the associated civil work and accessories from a pipeline resulting a reduction in total project cost and reduced potential indirect rework in coupling joint piping system installations.

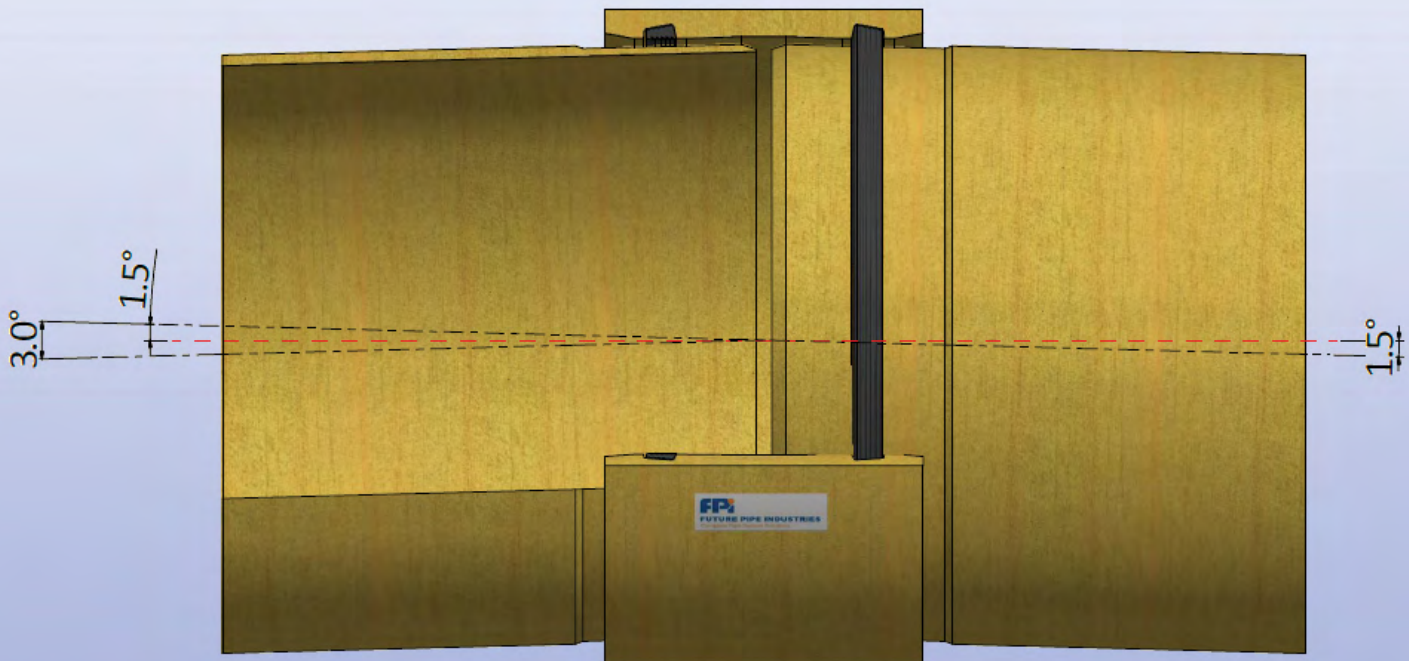

## ADVANTAGES:

The Use of New FPI Reka up to 3° Allowed Angular Deflection Joint has the following Characteristics:

- Allows the initial installation between two standard pipe sections to be done at a maximum angular deflection of 3°
- Allows either a horizontal or vertical shift in the center line of the pipe, owing to obstacle thus eliminating the need for fittings such as elbows and its accessories.
- Maintains the flexibility for an additional long-term settlement.
- Allows the elimination of individual small angle elbows up to 3° and the resulting required thrust blocks, short pipes, rubber wrapping and couplings
- Allows the elimination of higher angled elbows, when more than one joint is used
- Allows a maximum angular deflection of 3° across the joint for pipe sizes ranging from DN600 – 2500. For diameters above DN2500, a maximum angular deflection of 2.5° is achievable
- Allowance of maximum angular deflection of 3° is valid for gravity and pressure piping system up to design pressure of 16 Bar
- When used with standard pipe, absorbs higher allowance for structural settlements (under extreme cases) than standard coupling, eliminating the need to use multiple short pieces
- Design has the flexibility to modify the pipe ends at site
- Allows the use of shorter turning radius (up to 1/6th the current standard levels) thus resulting increase in the potential for eliminating large angled elbows
- Allows the continuation of installation sequence, reduces re-work and overcomes any installation delays due to site measurements, required lead time etc. for manufacturing and delivery of special elbows, thus improving project installation efficiencies

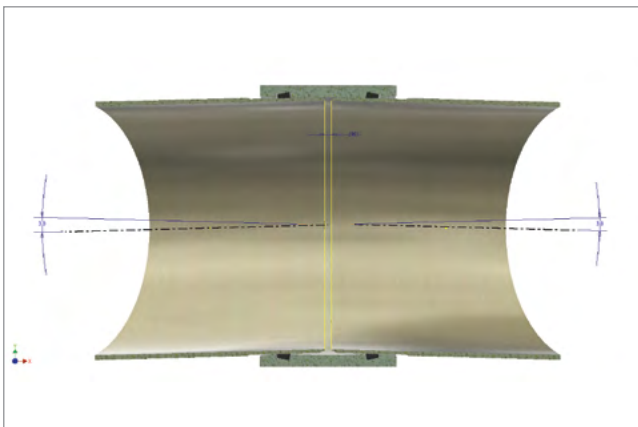

Figure 1: Double Bell and Spigot Joint with 3° Allowed Installation Angular Deflection

- Eliminates the need for keeping open sections along the installation route and the resulting need for adjustment pieces or concrete work / re-work due to site and weather conditions thus improving project installation efficiencies
- Allows the reduction of total project installation time

All the above is combined with the historical advantages of FPI Reka Joint like:

- Providing flexibility to the piping system from both sides of the joint
- Not transferring axial loads across the joint
- Ability to absorb relative rotation between the two joined pipes providing protection against vertical or lateral settlements and in case of seismic events
- Work like an expansion joint, allowing angular deflection, draw and offset
- Ease of assembly and use for installation adjustment
- Suitability for use in buried, trenchless, sub-aqueous, relining or exposed (e.g. inside chambers, encased or above ground)
- Can tolerate relatively high axial withdraw levels
- Ability to be used at tie-in connection with other piping material
- Ability to be used as a ground water sealing element at concrete penetration points

DN (mm)	DOS nominal (mm)	Home Line (mm)	Gap between pipe ends (mm)	Total Angular Deflection (°)
600	616.5	162	16	3
700	718.5	162	16	3
800	820.5	162	16	3
900	922.5	162	16	3
1000	1024.5	162	16	3
1100	1126.5	162	16	3
1200	1228.5	162	16	3
1300	1330.5	162	16	3
1400	1432.5	162	16	3
1500	1534.5	162	16	3
1600	1636.5	162	16	3
1700	1738.5	162	16	3
1800	1840.5	162	16	3
1900	1942.5	162	16	3
2000	2044.5	162	16	3
2100	2146.5	162	16	3
2200	2248.5	162	16	3
2300	2350.5	162	16	3
2400	2452.5	162	16	3
2500	2554.5	162	16	3