

FIBERGLASS TANKS
FOR UNDERGROUND STORAGE



FIBERGLASS TANKS
FOR UNDERGROUND STORAGE

Fiberglass (GRP) storage tanks mean lower total cost and greater dependability over the life of your storage system without maintenance.

There's one basic difference between Future Pipe Industries Fiberglass underground tanks and tank made from steel. Fiberglass tanks won't corrode.

A Fiberglass underground tank will last the life of most facilities without corrosion caused leaks or failures.

Corrosion-caused replacement costs are eliminated, as are periodic corrosion testing procedures, and the additional expense and concern over environmental problems due to leakage. Fiberglass Underground GRP Storage Tanks from Future Pipe Industries.



Long Life

Fiberglass underground GRP Storage tanks can be used to store gasoline, aviation fuel, gasohol (90% gasoline and 10% ethanol mixture), jet fuel, diesel fuel, potable water or waste water at ambient underground temperature, or fuel oil at temperatures not to exceed 1500F. Tanks to be used to store any other materials should be cleared with Future Pipe Industries Company before purchase and installation.

Fiberglass tanks are impervious to the effects of external corrosion. Because they will not leak due to corrosion. Fiberglass underground tanks eliminate worries over pollution and related environmental problems.

Corrosion is caused by a direct current discharge from underground steel tanks. There are two sources of corrosion of steel tanks: Galvanic Action and Stray Electrical currents.



Galvanic Action is an electrical cell phenomenon-which produces current. It is caused by such things as dissimilar metal, varying steel tank surface conditions and non-homogenous backfill. These conditions even vary within a single installation so that when testing oil resistivity, several tests must be made at different points of the same site over a period of time, to make the resistivity test results valid and useful. Conditions which indicate that corrosion will occur from galvanic action include: soil resistivity, soil pH, differential oxygen (different levels of oxygen exist at different points around steel tanks), new steel added to installation with old steel tanks, and anaerobic bacteria. Other variable factors, which may contribute to corrosion include: high water table, cinders, landfill, salts, fertilizers and septic tanks.

Stray Electrical currents are man-made. Through grounding, these man-made electrical currents return to their source, taking the path of least resistance. The current will travel along underground steel tanks, taking metal ions from the tank as the current discharges or leaves the tank, resulting in corrosion. Underground steel tanks are vulnerable to stray electrical current corrosion, even with well-designed external protection. There is no steel tank protective system that is effective against stray current corrosion.

Internal corrosion, contributing to many steel tank leaks and failures, is also eliminated with fiberglass underground tanks. External protection will do nothing to prevent internal corrosion. Factors which contribute to internal corrosion include: condensation from the product, oxygen, formation and deposition of sludge, climatic conditions, and the presence of bacteria.

Maintenance Free

Because Fiberglass tanks are not susceptible to corrosion, they're maintenance free. There's no need for periodic testing, record keeping or replacement of cathodic protection systems. You save the difference in time, money and concern over the service life of the tank and avoid potential financial liabilities.

Fiberglass underground tanks are made from polyester resins reinforced with glass fiber. Petroleum products stored in Fiberglass tanks may be easily changed, without affecting either the tank, or the new product. Common additives in stored products will not change or damage tanks.



Strong and Durable

Properly installed, Fiberglass tanks are strong enough to withstand constant traffic from the heaviest over-the-road vehicle (H-20 axle loads – 14,500 Kg/axle).

Fiberglass Underground Tanks were designed to meet specific performance criteria in dry or fully flooded holes when properly installed. An empty tank may be installed (with specified back-fill completely around tank) with 2 meters of water over the tank top with a 2:1 safety factor against external hydrostatic pressure.

All tanks must be vented, as tanks are designed for operation at atmospheric pressure only, except for use with vapor recovery systems provided the pressure or vacuum does not exceed 1 psi. Fiberglass tanks are designed for liquids with a specific gravity up to 1:1.

Safe for Drinking Water Storage

Future Pipe Industries underground tank are manufactured from Fiberglass (GRP) laminate certified by the Water Research Council (WRc) in the U.K.

Economical

Fiberglass underground tanks offer incomparable performance benefits combined with quick, easy installation.

The performance of a fiberglass underground tank means substantial savings over the life of the installation, compared to a steel tank. Fiberglass tanks mean no corrosion, no maintenance and no additional expense for tank replacement. In short, Fiberglass underground storage tanks are your lowest cost tanks.

GRP TANK – 1600MM DIA.

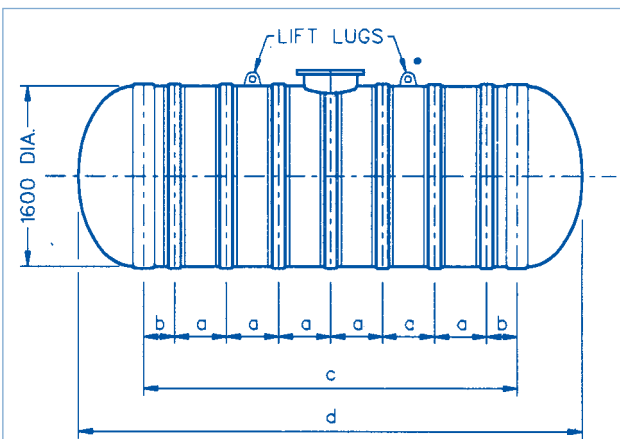

GRP TANK – 2000MM DIA

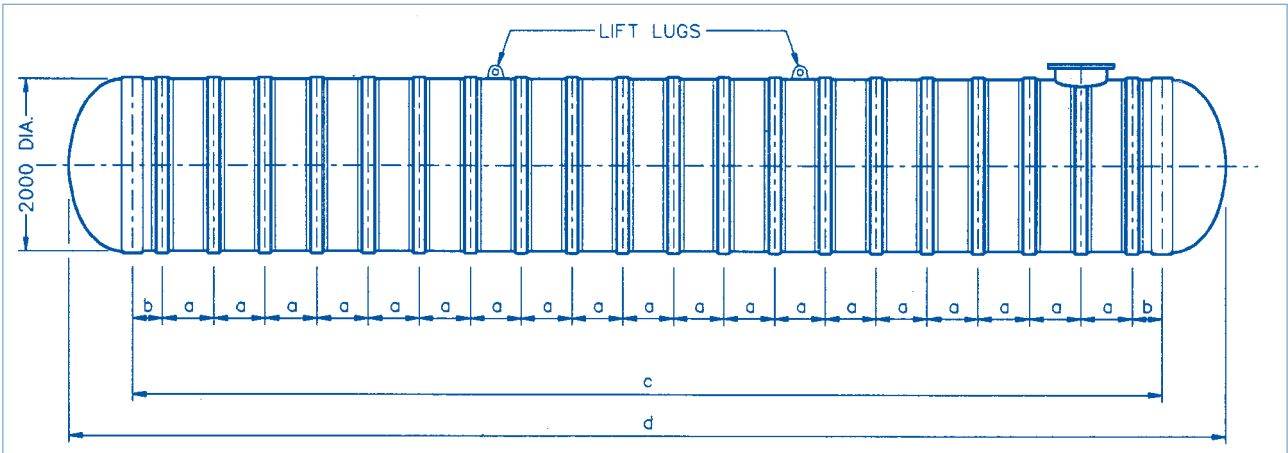

Volume	(Liter)	(I.G.)	13500	3000	22500	5000	30000	6600	37500	8000	9000	2000
Dia. (mm)			2000		2000		2000		2000		1600	
a			587		587		587		587		587	
b			481		533		320		437		349	
c			3897		6936		9444		12067		4220	
d			4937		7976		10484		13067		5053	
No. of RIBS			6		11		16		20		7	
Anchor Straps bet. Rib No.			1-2,5-6		1-2,5-6,10-11		1-2,5-6,11-12,16		1-2,10-11,19-20		1-2,6-7	
Lift Lugs bet. Rib No.			2-3,4-5		3-4,8-9		6-7,10-11		7-8,13-14		2-3,5-6	
Model Number			FPI/2000/13.5		FPI/2000/22.5		FPI/2000/30		FPI/2000/37.5		FPI/1600/9	

GRP TANK – 2400MM DIA

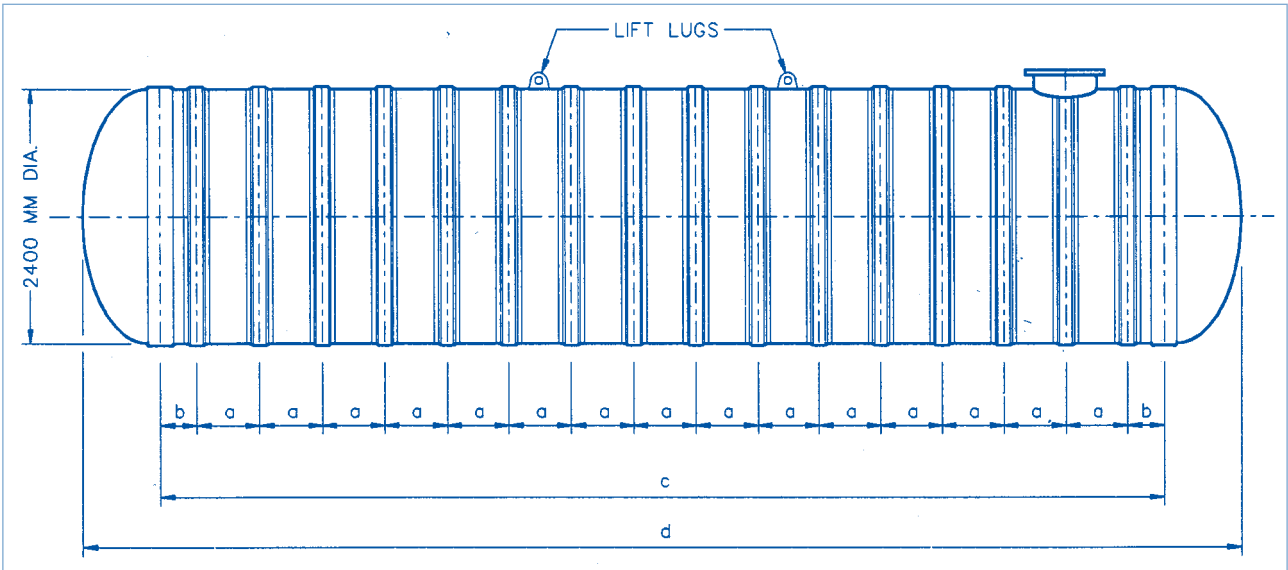

Volume	(Liter)	(I.G.)	22500	5000	37500	8000	45000	10000
a			587		587		587	
b			480		487		477	
c			4483		8018		9759	
d			5731		9266		11007	
No. of RIBS			7		13		16	
Anchor Strapsbet. Rib No.			1-2,6-7		1-2,6-7,12-13		1-2,5-6,11-12	
Lift Lugs Bet. Rib No.			2-3,5-6		4-5,9-10		6-7,10-11	
Model Number			FPI/2400/22.5		FPI/2400/37.5		FPI/2400/45	

GRP TANK – 2800MM DIA

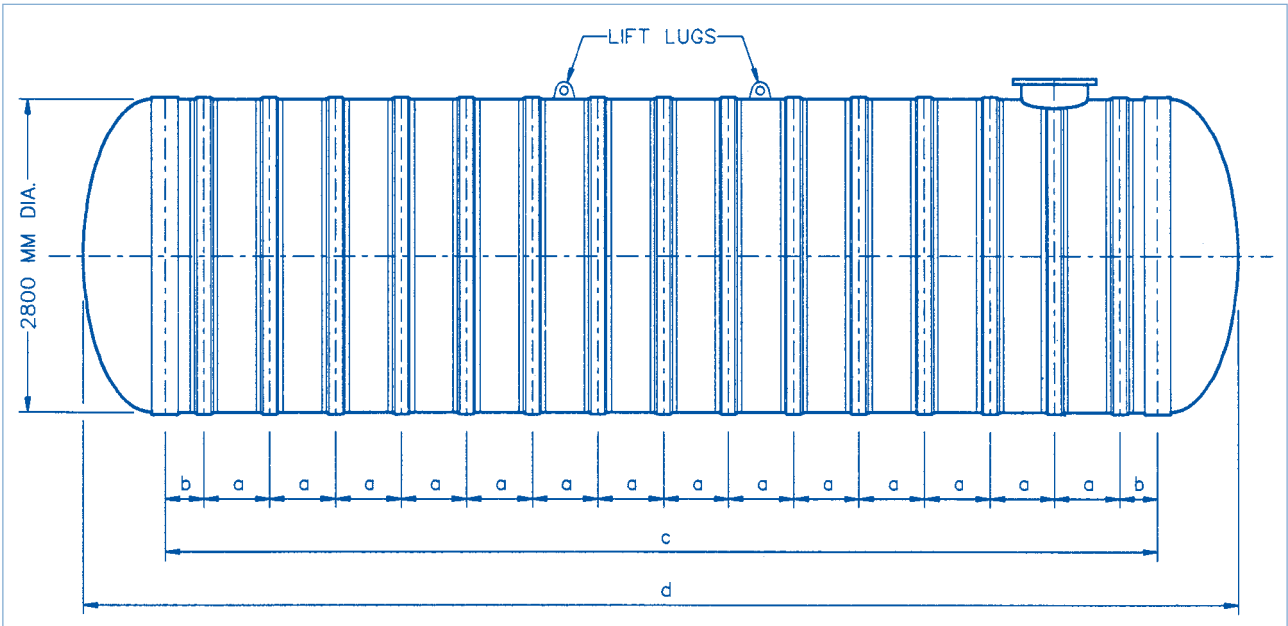

Volume	(Liter)	(I.G.)	13500	3000	22500	5000	30000	6600	37500	8000
a			587		587		587		587	
b			348		396		462		343	
c			3043		3726		6793		8904	
d			4500		5183		8250		10361	
No. of RIBS			5		6		11		15	
Anchor Straps bet. Rib No.			1-2,4-5		1-2,5-6		1-2,6-7,10-11		1-2,5-6,10-11,14-15	
Lift Lugs bet. Rib No.			1-2,4-5		2-3,4-5		4-5,7-8		6-7,9-10	
Model Number			FPI/2800/23		FPI/2800/27		FPI/2800/45		FPI/2800/68	

INSTALLATION INSTRUCTIONS FOR GRP UNDERGROUND STORAGE TANK

Fiberglass underground tank must be installed according to these instructions and NFPA 30 and 31. Local codes may apply and should be consulted. Failure to follow these installation instructions will void the warranty and may result in tank failure. Proper installation of Fiberglass underground tanks is required to prevent tank damage and to insure long-term corrosion resistant services. It is imperative to read, understand and follow the instructions below.

The presence of a Future Pipe Industries representative at the job site does not relieve the contractor of his responsibility to follow the published installation instructions. Any variances to the published installation instruction must be approved by Future Pipe Industries in writing prior to the tank installation.

Handing



Lifting Tanks: While lifting tanks use suitable nylon straps equally spaced along the length of the tank. Guide the tanks with guide ropes. **DO NOT STAND ON TANK WHILE TANK IS BEING LIFTED.**

DO NOT ROLL OR DROP TANK. Only use lifting equipment to move tanks. Capacity of lifting equipment must be checked before moving tanks. Set tanks on smooth ground, free of rocks and foreign objects and recheck.

Bed and Backfill

All excavated native soil must be replaced with approved backfill. **DO NOT MIX APPROVED GRAVEL WITH SAND OR NATIVE SOIL.** Always use approved gravel. Do not backfill in layers using sand or native soil.

If your backfill does not meet the specified requirements, alternate materials may not be used without written approval from Future Pipe Industries.

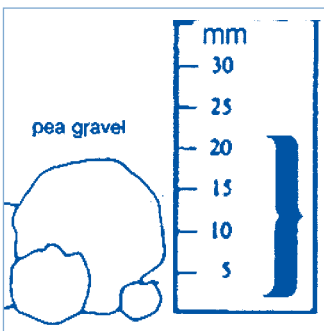

Gravel: A clean naturally rounded aggregate with a mix of particle sizes not less than 3mm or more than 20mm is required.

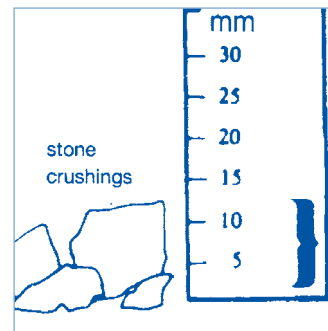

Crushed Stone or Crushed Gravel: Washed, crushed stone or gravel with angular particle size not less than 3mm or more than 12mm are required.

Note: All backfill material must meet ASTM C-33 paragraph 7.1 for quality and soundness. The backfill should not have more than 3% passing a # 8 sieve. The dry gravel density must be a minimum of 95 pounds per cubic foot.

Note: You should require your backfill supplier to certify that the backfill meets this specification.

Visual Air/Soap Testing

Before installing tanks, remove fitting plugs, apply pipe dope and then tighten fitting plugs. Pressure test 1600mm through 2800mm diameter tanks to 5 psi. soap the entire tank and fittings. The air test is of little value without soaping and a careful visual inspection for bubbles. Test at least 30 minutes to ensure there are no leaks as indicated by soap bubbles or a drop in pressure. Do not approach end caps or manways while tanks are under pressure. Before backfilling to grade, FPI recommend a 5 psi air/soap test on all finished piping connections and unused fittings.



Hole Size

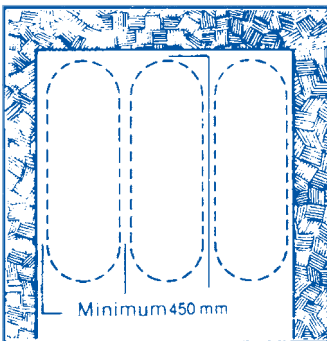

Stable walls (all size tanks)
In stable soil conditions the hole must be large enough to allow a minimum of 450mm (600mm preferred) between adjacent tanks and 450mm (600mm preferred) between the tank sides and ends and the tanks of the hole.

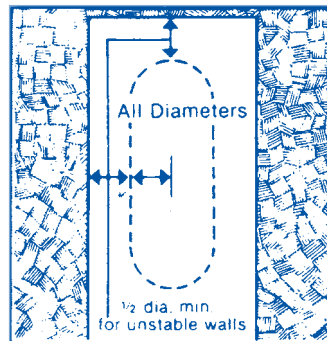

Unstable walls (all size tanks)
In muck, peat, swamp or landfill type areas where the soil is soft, a larger hole is required to support tanks. In these types of conditions the holes must be large enough to allow a minimum of 1/2 the tank diameter from ends and sides of tanks to hole walls.

Unstable soils are defined as those soils having less than 0.37 kg/cm² cohesion as calculated from an unconfined compression test; or soils with an ultimate bearing capacity of less than 1.71 kg/cm².

Unstable soils may require a reinforced concrete slab under tank for support.

For unstable soils with less than 0.12 kg/cm² cohesion or with an ultimate bearing capacity of less than 0.25 kg/cm², a filter fabric hole liner is recommended to prevent backfill migration. Refer to section 6.

Burial Depth and Cover

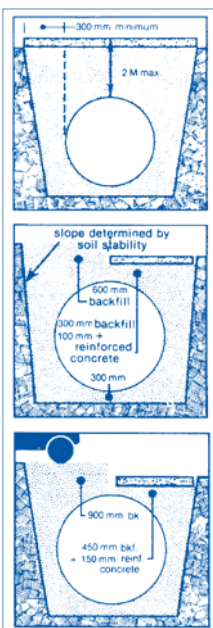

The tank hole must be deep enough to allow a minimum of 300mm required backfill bed cover over the hole bottom or concrete slab. If the total burial depth from tank top is greater than 60% of the tank diameter, anchoring the tanks is not required. (see section 9 for details).

PAD Dimensions:

Paving must extend at least 300mm beyond tank outline in all directions.

Maximum Burial Depth (all size tanks):

To comply with UL requirements, depth of cover for tanks in both traffic and no traffic conditions must not exceed 2m over tank top. For burial depths beyond 2m contact Future Pipe Industries.

Minimum Burial Depth No Traffic Loads (1600-2800mm Dia): Tanks not subjected to traffic loads need a minimum cover of 600mm backfill, or 300mm backfill plus 100mm reinforced concrete.

Traffic Load (1600mm – 2800mm Dia):

Tanks subject to traffic loads must have a cover depth of 900mm backfill or 450mm minimum backfill, plus 150mm of concrete reinforced with steel re-bars.

Filter Fabric – Wet Hole Liner

It is the responsibility of the tank owner or his technical representative to determine if filter fabric is appropriate for a specific tank installation. Our experience indicates that if all the other installation instructions are carefully followed, the use of filter fabric is not essential.

Filter fabric prevents the migration of pea gravel with native soil; it helps to maintain the integrity and stability of the backfill material. Future Pipe Industries recommends the use of filter fabric for the following types of installations:



1. Tidal conditions or areas subjected to frequently changing ground water levels.
2. Unstable soils (muck or landfills)
3. Water conditions with silty soil

Suitable brand name filter fabrics are itemized below:

- Manufacturer: DuPont
- Product: TYPAR 3401 or TYPAR 3341
- Manufacturer: Hoechst Fibers
- Product: TREVIR S1120 (hole depth less than 3m)
TREVIR S1127 (hole depth greater than 3m)
- Manufacturer: Exxon Geotex Tiles
- Product: TERRAM

Polyethylene is not considered an effective material to prevent migration of pea gravel and natives soil; it tears and will degrade in a wet hole environment.

Installation Procedure: Line the excavation sides and bottom with filter fabric. Overlap adjoining fabric panels at least 300mm. Place some backfill on top of the filter fabric in and around the excavation perimeter to hold the fabric in place. In wet hole installation, backfill ballast is necessary to sink and hold the filter fabric to the bottom of the excavation.

Installation Procedure – Dry Hole

Bed: Provide a minimum of 300mm level approved backfill bed (see Section 1) over hole bottom or concrete slab. Set tanks on bed. **DO NOT PLACE TANKS DIRECTLY ON CONCRETE SLAB, TIMBERS, BEAMS OR CRADLES.**

Backfilling (1600mm – 2800mm Dia): Use same materials as bedding. Place first 300mm lift evenly around tanks. From the bank or adjacent tank top, backfill must be moved completely beneath tank bottom, between ribs and under end caps to fill voids to provide necessary support. A long handled probe can be used to penetrate backfill and move it between all ribs and at three points under end caps. The backfill may be shoveled beneath the tank. Place another 300mm lift of backfill evenly around tanks. Repeat the probing of backfill from the bank or adjacent tank top.

After completion of second lift, backfill can be brought to top of tanks or grade without additional hand work. (Compaction may be required for slab support).

This method will not work in tight areas in straight-walled holes. The angle necessary to probe the backfill under the tank cannot be made with the long-handled probe. Straight walled holes in tight areas will require a curved probe to backfill under the tanks.

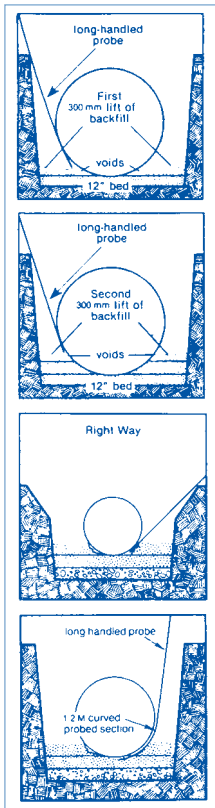

The curved probe is a 1.2m section of the long handled aluminum probe bent on a radius to match the tank curvature. A leveraging action on the long-handled probe creates a pushing action under the tank bottom.

The following procedures are the most effective for the curved probe:

- After setting the tank on the gravel bed. Probe the area tank bottom and around the end caps.
- Place the first 300mm lift of backfill.
- Probe the entire tank bottom and end caps again.
- Place the second 300mm lift of backfill.
- Switch to straight probe section and probe tank again.

Note: Tanks installed with backfill to top of tank, but without backfill to grade should be completely filled with water or product as ballast. Do not place water or product in tank until backfill is even with tank top.

Installation Procedure – Wet Hole

A filter fabric separator may be appropriate to prevent gravel migration. Refer to section 6 for details. Water level should be maintained at lowest practical level by using pumps with or without a well-point systems. Prepare bed as outlined in section 7.

Ballast

If the water cannot be lowered, you will have to ballast tanks. Place tanks in the hole, adding only enough ballast to sink them. Ballast level in tanks must never exceed water level in hole during installation. While adding ballast, use only lifting cable to keep tanks in positions. Tanks should be free to roll slightly.

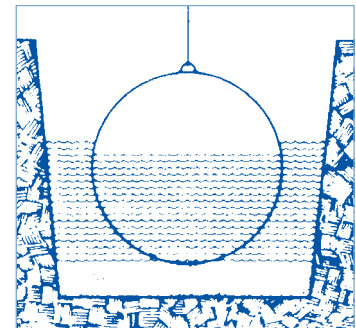

Backfilling

Distribute backfill evenly around tanks as outlined in Section 7.

Anchoring

It is responsibility of the tank owner to his technical representative to determine if mechanical anchoring is required for a specific job site. All potential sources of water (underground water table, rain water table, rain water run-off, etc...) should be considered.

If water could enter the tank hole, Future Pipe Industries recommends the tanks be mechanically anchored unless the minimum burial depth from tank top is as follows:

Tank Diameter	Minimum buried depth when mechanical anchoring is not required	
	Concrete Traffic Slab Thickness	
	0mm	150mm
1600mm	980mm	790mm
2000mm	1140mm	1070mm
2400mm	1370mm	1300mm
2800mm	1750mm	1680mm

At the above burial depths, the overburden directly above the tank weights more than the buoyancy of the empty tank with water to grade (safety factor equals 1.2). For burial depths where mechanical anchoring is recommended, either of two common methods can be used: a concrete anchor pad or deadman anchors. Both methods include the use of anchor straps.

Strapping

Use hold-down straps, anchor points should be spaced equal to tank diameter plus 300mm each side of tank, regardless of tank diameter. Anchor points at bottom of hole must be aligned with location of straps ± 25 mm.

All anchor straps must be uniformly tightened with turnbuckles or come-a-longs. Straps should be snug but cause no tank deflection.

Deflection can be detected by checking tank diameter with a gauge stick before and after snugging straps. Triple clamp the wire rope.

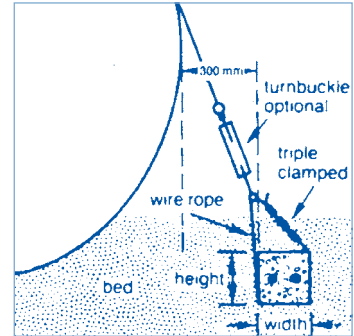

Concrete Anchor Pad

The weight of overburden on top of the concrete slab provides the anchoring force. This pad design is strictly for buoyancy. Poor soil conditions may require increased reinforcement and slab size. Anchor hold-down devices in concrete and attach them to ends of straps with wire cable (see table at end of this section) and clamp with at least two clamps. (be sure there is a 300mm bed between concrete pad and tanks).

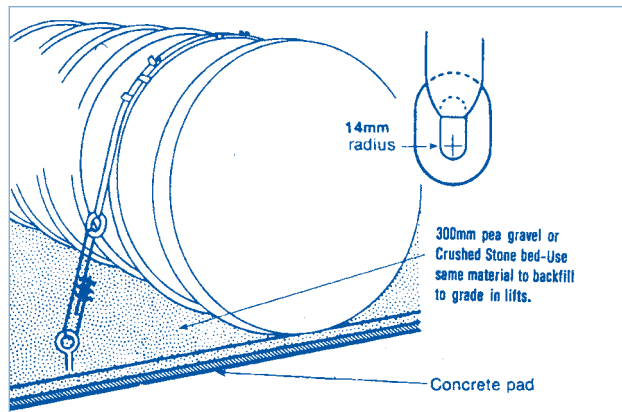
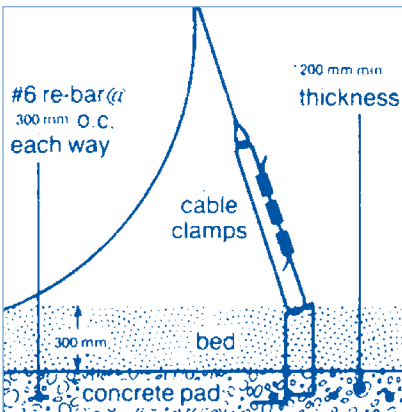

Deadman Anchors

The weight of overburden on top of deadman and tank provides the anchoring force, lay deadman along each side and parallel to tank. The tank must not overshadow the deadman anchor. Clamp wire with at least three clamps around deadman and through end of strap.

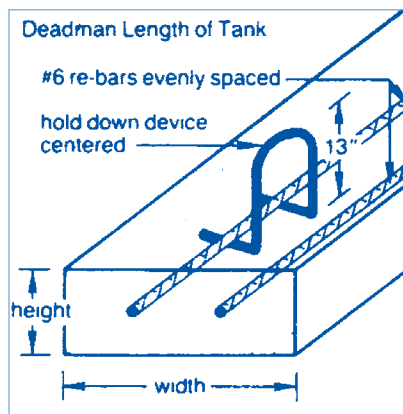
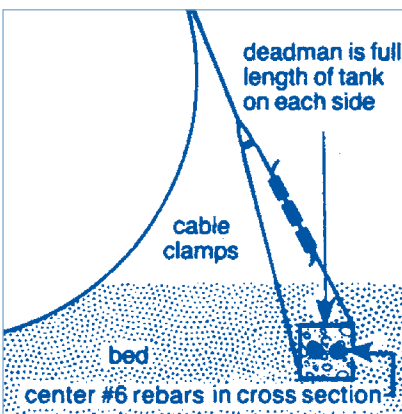

Deadman are made with reinforced (2-6 rebars) concrete. The cross section dimensions may vary depending on burial depth. Contact Future Pipe Industries for details. If burial depth is 600mm deadman size is as follows:

Tank Diameter (mm)	Minimum Height (mm)	Width (mm)*
1600	300	300
2000	300	300
2400	300	350
2800	300	450

*A round cross section can be substituted if the diameter equals or exceeds the deadman width.

When using deadman anchors in multiple tank installations, each tank will require two deadman. If one deadman is used for adjacent tanks it must be doubled in width. A separate anchor point (hold down device) must be provided for each strap. Holds down devices are incorporated with their legs anchored under the re-bar reinforcement. Spacing for these hold-down devices is determined by the number of anchor points shown on tank drawings.

The hold down device can be fabricated from rebar as follows:

Tank Diameter (mm)	Rebar Size (mm) (1 Strap/anchor point)	Minimum Rebar Width (mm)
1600, 2000	20	115
2400	24	200
2800	32	200

Turnbuckles (Optional)

Hook, Jaw or eye-type turnbuckles may be used in place of all or a portion of the wire rope described in this section.

Tank Diameter (mm)	1600, 2000	2400, 2800
Turnbuckle Diameter		
Hook Type	20	32
Jaw Type	12	20
Eye Type	12	20
Wire Rope Diameter		
6x19 (improved plow steel)	10	12

Note: Tanks installed with backfill to top of tank, but without backfill to grade should be completely filled with water or product in tank until backfill is even with tank top.

Fiberglass tanks can be anchored safely by using burial depth and a surface slab to offset the buoyancy factors. For alternate anchoring methods refer to Future Pipe Industries specifications.

PUMPING AND SUMP CLEARANCE



Tanks with Sumps

When installing tank equipped with a sump, excavating and bedding must be modified to provide a 300mm x 600mm diameter hole centered at the sump location.

After the tank is placed, the void surrounding the sump is to be hand backfilled and hand tamped prior to adding backfill around the tank.

Fiberglass Sump

Fiberglass Sumps are available to facilitate condensation removal. The sumps are 100mm deep, and must be installed between ribs along centerline of tank bottom and are limited to one sump per tank. Special installation procedures must be followed when installing tanks with sumps.

Sumps are available for all tank sizes.

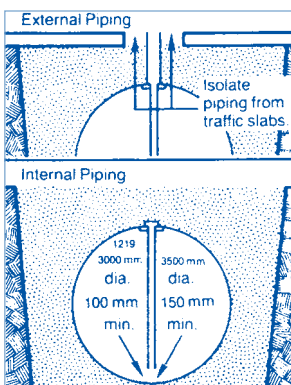
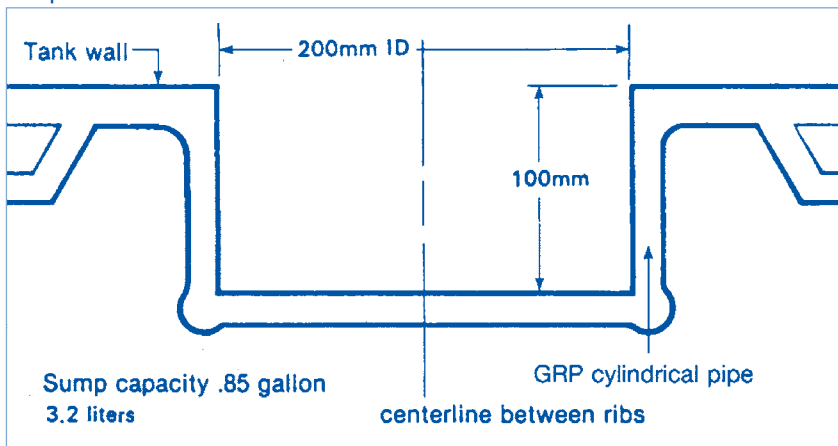

External Piping

The pump and attached piping must be free to move with the tank. Use a fill box or street box to isolate the piping from the traffic pad.

Internal Piping

Internal piping must be a minimum of 100mm from the tank bottom.

Filling tanks

Do not fill until backfill is top of tank. Never add product or water for hold-down in dry hole conditions until the backfilling is completed (exception, see installation procedure – wet hole).

Venting

Tanks must be vented with an opening the same diameter or larger than the piping used to remove product.

Manway and Manway Extensions

The standard manway is 600mm in diameter and has a load bearing capacity of 545 kg. optional heavy duty manways have a load bearing capacity of 1090 kg.

Manway Risers

The fiberglass manway riser provides a non-corroding, spacious access from a manhole box and cover. Since the bottom is open, the manway riser will fill water as water surrounds it on the outside. Traffic areas require a reinforced concrete traffic pad.

A maximum of 2 manway risers may be used with tank sizes of 8000 gallons and larger; only one riser is permitted with tanks sizes less than 8000 gallons due to possible buoyant forces.

The riser must be installed with 150mm minimum clearance from the top of the tank. The bottom of the riser should be supported with 50x100x80mm minimum wood pieces.

Barricades

Tank area must be barricaded to prevent any vehicle travel over the tanks until installation is complete.

TYPICAL MANHOLE COVER

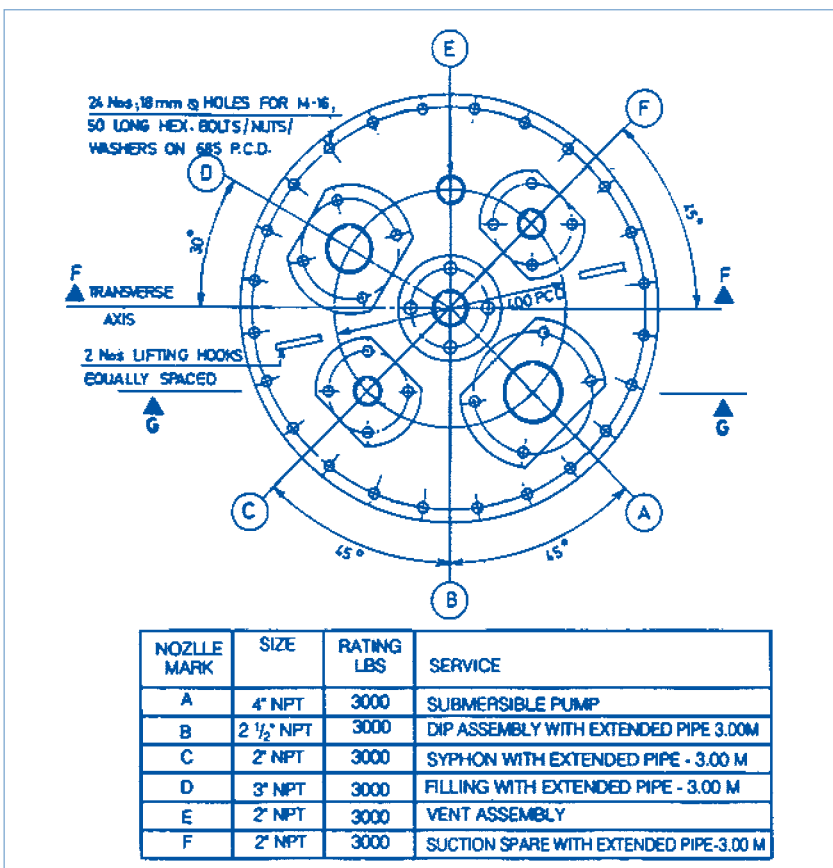

Fiberglass Manway Riser Pipe

The fiberglass manway riser pipe provides a non-corroding, spacious, economical access from a manhole box and cover (traffic area require reinforced concrete road surface) down to the tank manway. Since the bottom is open, the manway riser will fill with water as water surrounds it on the outside.

The manway riser pipe is available in lengths from 750mm to 1350mm in 150mm increments, and consists of a 1200mm diameter tube, open at one end and a600mm centered square hole with rounded corners at the other end.

A maximum of two manway risers may be used with tank sizes of 10,000 gallons and larger; only one riser is permitted with tank sizes less than 10,000 gallons due to possible buoyant forces.

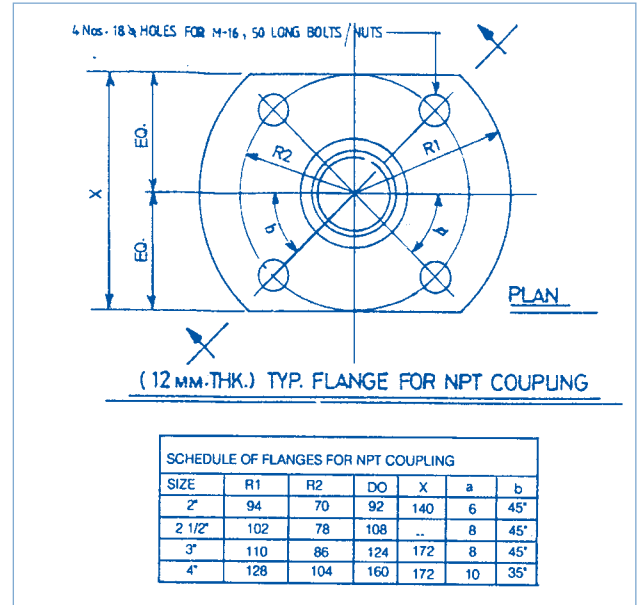
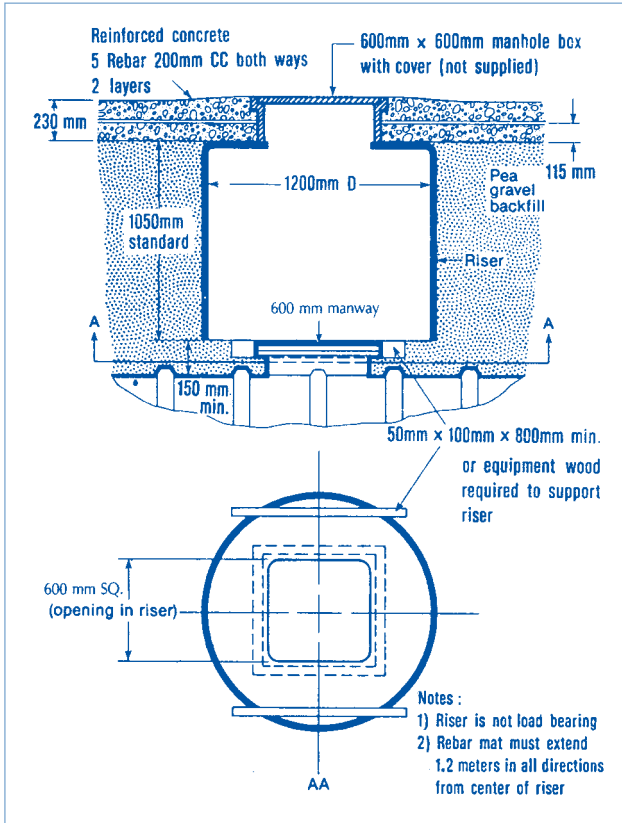

Tand ladders

Fiberglass tanks are available with a factory installed ladder. Attached slip lugs on the trunk of the manway. (Manway and ladder are sold separately).

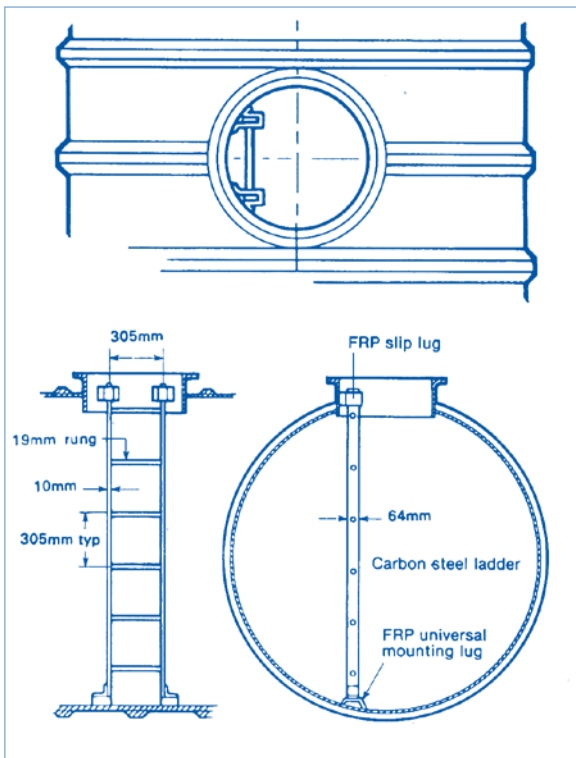

Fiberglass Standard Flanged Manways

Manways can be installed centered over any of the tank ribs except for end ribs, the standard manway (bearing loads to 550 kg) is 600 mm in diameter equipped with black carbon steel and includes a gasket and 24 1/2" x 1 1/2" bolts, nuts and washers. Fiberglass extension tubes 600 mm diameter are available in 600mm length which include extra gasket and set of nuts, bolts and washers.

